

# CM4A H00 SERIES

## Current Sensor

### Model Number:

CM4A 1000 H00

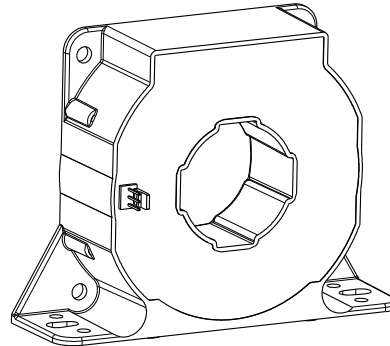

For the electronic measurement of current: DC, AC, pulsed..., with galvanic separation between the primary and the secondary circuit.

### Features

- ✧ Closed loop (compensated) current sensor using the Hall effect
- ✧ Galvanic separation between primary and secondary
- ✧ Insulating plastic case recognized according to UL 94-V0
- ✧ Very good linearity
- ✧ High accuracy
- ✧ Very low offset drift over temperature
- ✧ No insertion loss
- ✧ Standards:
  - EN50178: 1997
  - IEC 61010-1: 2000
  - UL 508: 2010

### Applications

- ✧ AC variable speed and servo motor drives
- ✧ Uninterruptible Power Supplies (UPS)
- ✧ Static converters for DC motor drives
- ✧ Switch Mode Power Supplies (SMPS)
- ✧ Power supplies for welding applications
- ✧ Battery management
- ✧ Wind energy inverter
- ✧ Test and detection devices

## Safety

This sensor must be used according to IEC61010-1.

This sensor must be used in electric/electronic equipment with respect to applicable standards and safety requirements in accordance with the manufacturer's operating instructions.

**Caution, risk of electrical shock!**



When operating the sensor, certain parts of the module can carry hazardous voltage (e.g., Primary busbar, power supply). Ignore this warning can lead to injury and/or cause serious damage. This sensor is a built-in device, whose conducting parts must be inaccessible after installation. A protective housing or additional shield could be used.

Main supply must be able to be disconnected.

# CM4A H00 SERIES

## Absolute maximum ratings(not operating)

Parameter	Symbol	Unit	Value
Supply voltage	$V_C$	V	± 25.2
Primary conductor temperature	$T_B$	°C	100
ESD rating, Human Body Model (HBM)	$V_{ESD}$	kV	4

- ※ Stresses above these ratings may cause permanent damage.
- ※ Exposure to absolute maximum ratings for extended periods may degrade reliability.

## Environmental and mechanical characteristic

Parameter	Symbol	Unit	Min	Typ	Max	Comment
Ambient operating temperature	$T_A$	°C	-40		85	
Ambient storage temperature	$T_S$	°C	-40		90	
Mass	$m$	g		615		
Standards	EN 50178, IEC 61010-1, UL 508C					

## Insulation coordination

Parameter	Symbol	Unit	Value	Comment
Rms voltage for AC insulation test, @50 Hz, 1 min	$V_d$	kV	3.8	
Impulse withstand voltage 1.2/50µs	$V_w$	kV	16	
Clearance (pri.- sec.)	$d_{cl}$	mm	19.6	
Creepage distance (pri.- sec.)	$d_{cp}$	mm	20.6	
Plastic case	-	-	UL94-V0	
Comparative tracking index	$CTI$	PLC	3	
Application example	-	-	1000V CAT III PD2	Reinforced insulation, according to EN 50178, EN 61010-1
Application example	-	-	2000V CAT III PD2	Basic insulation, according to EN 50178, EN61010-1

# CM4A H00 SERIES

## Electrical data

✘ With  $T_A = 25^\circ\text{C}$ ,  $V_C = \pm 24\text{V}$ ,  $R_M = 20\Omega$ , unless otherwise noted.

Parameter	Symbol	Unit	Min	Typ	Max	Comment
Primary nominal rms current	$I_{PN}$	A	-1000		1000	
Primary current, measuring range	$I_{PM}$	A	-2100		2100	
Measuring resistance	$R_M$	$\Omega$	0		16	@ $\pm 15\text{V}$ , $85^\circ\text{C}$ , $\pm 1000\text{A}$
			0		4	@ $\pm 15\text{V}$ , $85^\circ\text{C}$ , $\pm 1200\text{A}$
			10		54	@ $\pm 24\text{V}$ , $85^\circ\text{C}$ , $\pm 1000\text{A}$
			10		1	@ $\pm 24\text{V}$ , $85^\circ\text{C}$ , $\pm 2100\text{A}$
Secondary nominal rms current	$I_{SN}$	mA	-200		200	
Secondary coil resistance	$R_S$	$\Omega$			39	@ $25^\circ\text{C}$
					51	@ $85^\circ\text{C}$
Secondary current, measuring range	$I_S$	mA	-420		420	
Number of secondary turns	$N_S$	-		5000		
Theoretical sensitivity	$G_{th}$	mA/A		0.2		
Supply voltage	$V_C$	V	$\pm 15$		$\pm 24$	@ $\pm 5\%$
Current consumption	$I_C$	mA		$28 + I_S$		
Offset current	$I_0$	mA	-0.2		0.2	
Thermal drift of offset current	$I_{0T}$	mA	-0.6		0.6	@ $-40^\circ\text{C} \sim 85^\circ\text{C}$
Residual current@ $I_P=0$ after $I_{PN}$	$I_{0M}$	mA	-0.1		0.1	
Sensitivity error	$\varepsilon_G$	%	-0.2		0.2	Exclusive of $I_{0E}$
Linearity error 0... $I_{PN}$	$\varepsilon_L$	% of $I_{PN}$	-0.1		0.1	Exclusive of $I_{0E}$
Accuracy@ $I_{PN}$	$X$	% of $I_{PN}$	-0.3		0.3	Exclusive of $I_{0E}$
Response time@ 90% of $I_{PN}$	$t_r$	$\mu\text{s}$		0.5	1	
Frequency bandwidth(-3dB)	$BW$	kHz	150			

# CM4A H00 SERIES

Dimensions (in mm. 1 mm = 0.0394 inch)

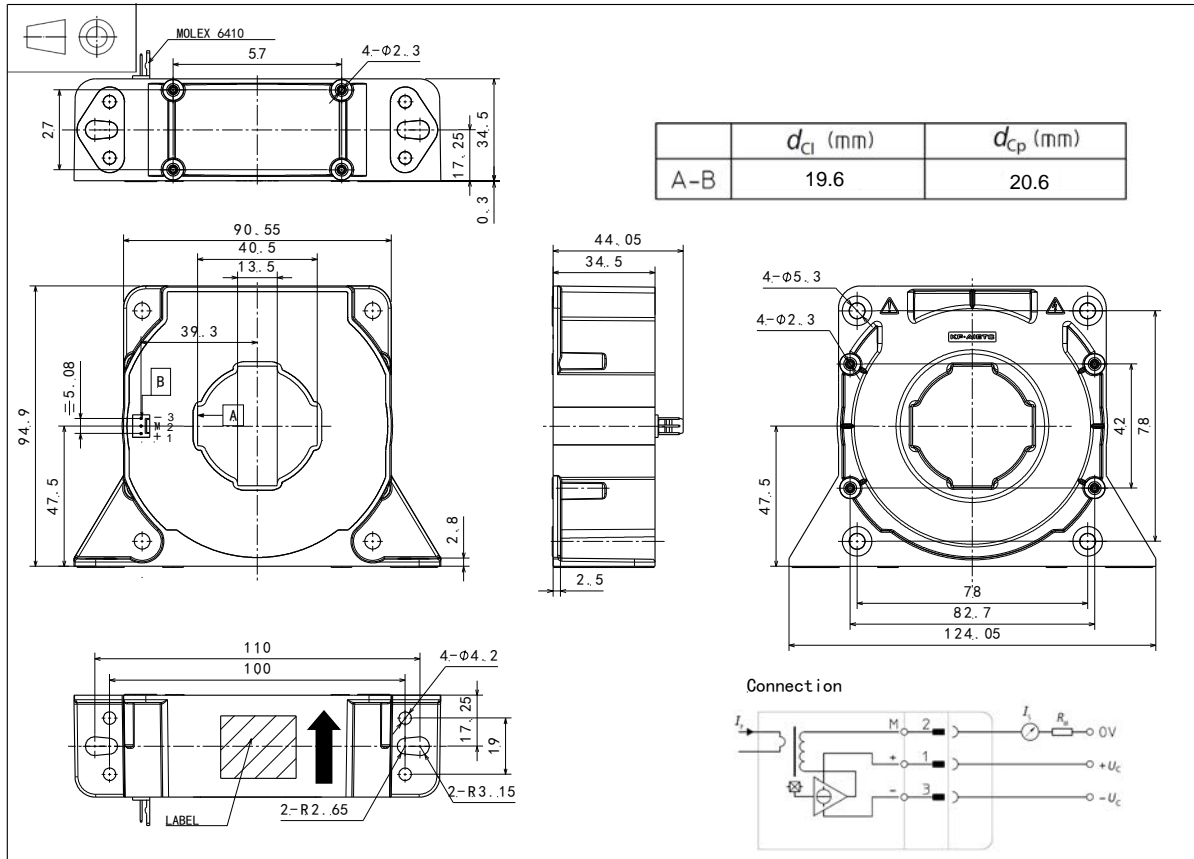

## Mechanical characteristics

- ◇ General tolerance  $\pm 0.5\text{mm}$
- ◇ Primary hole  $\Phi 38\text{mm}$   
40 mm x 13 mm
- ◇ Transduce vertical fastening 2pc  $\Phi 5.3\text{ mm}$  through hole  
2pc M5 metal screw

Recommended fastening torque  $1.2\text{ N}\cdot\text{m}$  ( $\pm 10\%$ )  
or  
4pc  $\Phi 4.2\text{ mm}$  through hole  
4pc M4 metal screw  
Recommended fastening torque  $0.9\text{ N}\cdot\text{m}$  ( $\pm 10\%$ )

◇ Connection of secondary Molex 6410

◇ Transduce horizontal fastening  
4pc  $\Phi 5.3\text{ mm}$  through hole  
4pc M5 metal screw

Recommended fastening torque  $1.2\text{ N}\cdot\text{m}$  ( $\pm 10\%$ )

## Remarks

- ◇  $I_S$  and  $I_P$  are in the same direction, when  $I_P$  flows in the direction of arrow.
- ◇ Temperature of primary conductor should not exceed  $100^\circ\text{C}$ .
- ◇ Dynamic performances ( $di/dt$  and response time) are best with a single bar completely filling the primary hole.

This is a standard model. For different applications (measurement, secondary connections...), please contact CHIPSENSE.